

## Applications

- For gaseous, dry and non-aggressive media that do not attack copper alloys
- Gas-, Vacuum-, Environment-, Laboratory-technology, for content measurement and filter monitoring

## Special features

- With zero-point correction
- Very good price / performance ratio



Capsule pressure gauge

## Description

RIEGLER capsule pressure gauges, which are suitable for low pressures and used for fine measuring ranges in gas technology are based on the proven capsule spring measuring system. Two concentrically formed membranes are joined at their outer edges by welding or soldering. One membrane has an opening at its center into which the gas to be measured can flow.

The pressure created in the capsule spring causes it to arch outwards. A bell crank mounted opposite to the input opening directs the linear motion to a pointer mechanism and converts it into a circular motion.

## Technical data

### Design

EN 837-3

### Nominal size in mm

63

### Accuracy class (EN 837-3/6)

1,6

### Scale ranges

-160 ... 0 mbar to -60 ... 0 mbar

0 ... 40 mbar to 0 ... 400 mbar

(Connection position radially down or axially centric)

### Pressure resilience

Dormant load: full scale value

Dynamic resilience: 0,9x full scale value

Overload protection: 1,3x full scale value

### Permissible temperature

Medium: Tmax = +60 °C

Environment: Tmin = -20 °C

Tmax = +60 °C

### Temperature influence

Indication error in case of deviation from the normal temperature of 20 °C at the measuring system:

For temperature increase approximately:  $\pm 0,6 \%/10 \text{ K}$ ,For temperature decrease approximately:  $\pm 0,6 \%/10 \text{ K}$ 

from the respective full scale value

### Ingress protection per IEC / EN 60529

IP 33

### Process connection

Brass, radial or axial centric

G1/4B – AF14

### Measuring element

Capsule spring, Copper-Beryllium alloy

### Sealing

NBR (Perbunan)

### Pointer

Aluminium, black

### Window

Plastic, clipped-in

### Case

Steel plate, black

### Dial

Aluminium, white,

Black scale

### Zero point setting

In front

### Pointer mechanism

Brass

## Dimensions in mm

### Connection radial

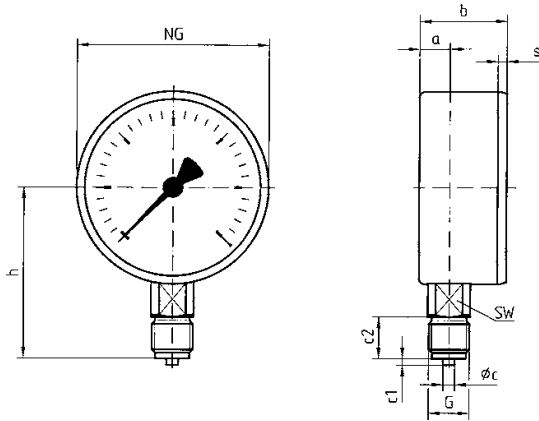

NG	Dimensions in mm										Weight in kg
	a	b	$\phi_c$	c <sub>1</sub>	c <sub>2</sub>	G	h	S	AF		
63	9,5	33,7	5	2	13	G ¼ B	52,7	3,7	14	0,19	

### Connection axial

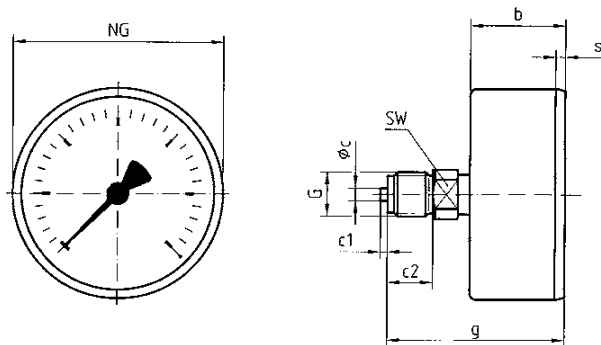

NG	Dimensions in mm									Weight in kg
	b	$\phi_c$	c <sub>1</sub>	c <sub>2</sub>	G	g	s	AF		
63	33,7	5	2	13	G ¼ B	56,7	3,7	14	0,18	